



Visualisation; Diagnostics

Easy to Configure

Programming IEC 61131-3

Rapid Installation

PSEN cs1.19n

PILZ

THE SPIRIT OF SAFETY

► PSEN sensor technology

This document is a translation of the original document.

All rights to this documentation are reserved by Pilz GmbH & Co. KG. Copies may be made for internal purposes. Suggestions and comments for improving this documentation will be gratefully received.

Source code from third-party manufacturers or open source software has been used for some components. The relevant licence information is available on the Internet on the Pilz homepage.

Pilz®, PIT®, PMI®, PNOZ®, Primo®, PSEN®, PSS®, PVIS®, SafetyBUS p®, SafetyEYE®, SafetyNET p®, the spirit of safety® are registered and protected trademarks of Pilz GmbH & Co. KG in some countries.



SD means Secure Digital

Introduction	5
Validity of documentation	5
Using the documentation	5
Definition of symbols	5
Safety	6
Intended use	6
Safety regulations	7
Safety assessment	7
Use of qualified personnel	7
Warranty and liability	7
Disposal	7
For your safety	8
Unit features	8
Function description	8
Block diagram	9
Operating distances	9
Lateral and vertical offset	10
Distance between actuators	11
Wiring	11
Pin assignment, connector and cable	12
Connection to evaluation devices	12
Teaching in the actuator	14
Installation	14
Adjustment	15
Operation	15
Error display through flashing codes	16
Dimensions in mm	18
Technical details	18
Safety characteristic data	21
Supplementary data	23
Radio approval	23
Order reference	23
System	23
Accessories	23

EC declaration of conformity	24
-------------------------------------	-----------

Introduction

Validity of documentation

This documentation is valid for the product PSEN cs1.19n. It is valid until new documentation is published.

This operating manual explains the function and operation, describes the installation and provides guidelines on how to connect the product.

Using the documentation

This document is intended for instruction. Only install and commission the product if you have read and understood this document. The document should be retained for future reference.

Definition of symbols

Information that is particularly important is identified as follows:



DANGER!

This warning must be heeded! It warns of a hazardous situation that poses an immediate threat of serious injury and death and indicates preventive measures that can be taken.



WARNING!

This warning must be heeded! It warns of a hazardous situation that could lead to serious injury and death and indicates preventive measures that can be taken.



CAUTION!

This refers to a hazard that can lead to a less serious or minor injury plus material damage, and also provides information on preventive measures that can be taken.



NOTICE

This describes a situation in which the product or devices could be damaged and also provides information on preventive measures that can be taken. It also highlights areas within the text that are of particular importance.

**INFORMATION**



This gives advice on applications and provides information on special features.

Safety**Intended use**

Safety function of safety switch:

- ▶ 2 safety outputs each supply a high signal, depending on which actuator is in the safety switch's response range (see [Function description](#)  8).

The safety switch meets the requirements in accordance with:

- ▶ EN 60947-5-3 with the actuator PSEN cs1.19: PDDb
- ▶ EN 62061: Up to max. SIL CL 3 (see [Safety characteristic data](#)  21)
- ▶ EN ISO 13849-1: PL e (Cat. 4) (see [Safety characteristic data](#)  21)
- ▶ EN ISO 14119: Coding level Low, Type 4

The safety switch may only be used with the corresponding actuators PSEN cs1.19 (OSSD1, OSSD2, OSSD1&2).

The safety level PL e (Cat. 4)/SIL CL 3 (see [Safety-related characteristic data](#)  21) is only achieved if

- ▶ the safety outputs use 2-channel processing
- ▶ the actuators are used in accordance with the details stated in the safety-related characteristic data.

The following is deemed improper use in particular:

- ▶ Any component, technical or electrical modification to the product
- ▶ Use of the product outside the areas described in this manual
- ▶ Use of the product outside the technical details (see [Technical details](#)  18).

**NOTICE****EMC-compliant electrical installation**

The product is designed for use in an industrial environment. The product may cause interference if installed in other environments. If installed in other environments, measures should be taken to comply with the applicable standards and directives for the respective installation site with regard to interference.

Safety regulations

Safety assessment

Before using a unit it is necessary to perform a safety assessment in accordance with the Machinery Directive.

Functional safety is guaranteed for the product as a single component. However, this does not guarantee the functional safety of the overall plant/machine. In order to achieve the required safety level for the overall plant/machine, define the safety requirements for the plant/machine and then define how these must be implemented from a technical and organisational standpoint.

Use of qualified personnel

The products may only be assembled, installed, programmed, commissioned, operated, maintained and decommissioned by competent persons.

A competent person is a qualified and knowledgeable person who, because of their training, experience and current professional activity, has the specialist knowledge required. To be able to inspect, assess and operate devices, systems and machines, the person has to be informed of the state of the art and the applicable national, European and international laws, directives and standards.

It is the company's responsibility only to employ personnel who

- ▶ Are familiar with the basic regulations concerning health and safety / accident prevention,
- ▶ Have read and understood the information provided in this description under "Safety"
- ▶ Have a good knowledge of the generic and specialist standards applicable to the specific application.

Warranty and liability

All claims to warranty and liability will be rendered invalid if

- ▶ The product was used contrary to the purpose for which it is intended
- ▶ Damage can be attributed to not having followed the guidelines in the manual
- ▶ Operating personnel are not suitably qualified
- ▶ Any type of modification has been made (e.g. exchanging components on the PCB boards, soldering work etc.).

Disposal

- ▶ In safety-related applications, please comply with the mission time T_M in the safety-related characteristic data.
- ▶ When decommissioning, please comply with local regulations regarding the disposal of electronic devices (e.g. Electrical and Electronic Equipment Act).

For your safety



WARNING!

Loss of safety function due to manipulation of the interlocking device

Manipulation of the interlocking device may lead to serious injury and death.

- You should prevent any possibility of the interlocking device being manipulated through the use of a spare actuator.
- Keep the substitute actuator in a safe place and protect it from unauthorised access.
- If spare actuators are used, these must be installed as described in [Installation](#) [ 14].
- If the original actuators are replaced with substitute actuators, the original actuators must be destroyed before disposal.

- ▶ Do not remove the connector's protective cap until you are just about to connect the unit. This will prevent potential contamination.

Unit features

- ▶ Transponder technology for presence detection
- ▶ Pilz coding type: Coded
- ▶ Dual-channel operation
- ▶ 2 safety outputs
- ▶ 3 actuators
- ▶ LED display for:
 - State of the actuator
 - Supply voltage/fault
- ▶ 4 directions of actuation
- ▶ 5-pin M12 male connector

Function description

The safety outputs may have a high or low signal, depending on the position of the actuator.

In a safe condition there is a low signal at the safety outputs.

State of the outputs:

Actuator in the re- sponse range	Safety out- put 12	Safety output 22	LED OSSD1	LED OSSD2
OSSD1	High	Low	☉	●
OSSD2	Low	High	●	☉
OSSD1&2	High	High	☉	☉
---	Low	Low	●	●

Block diagram

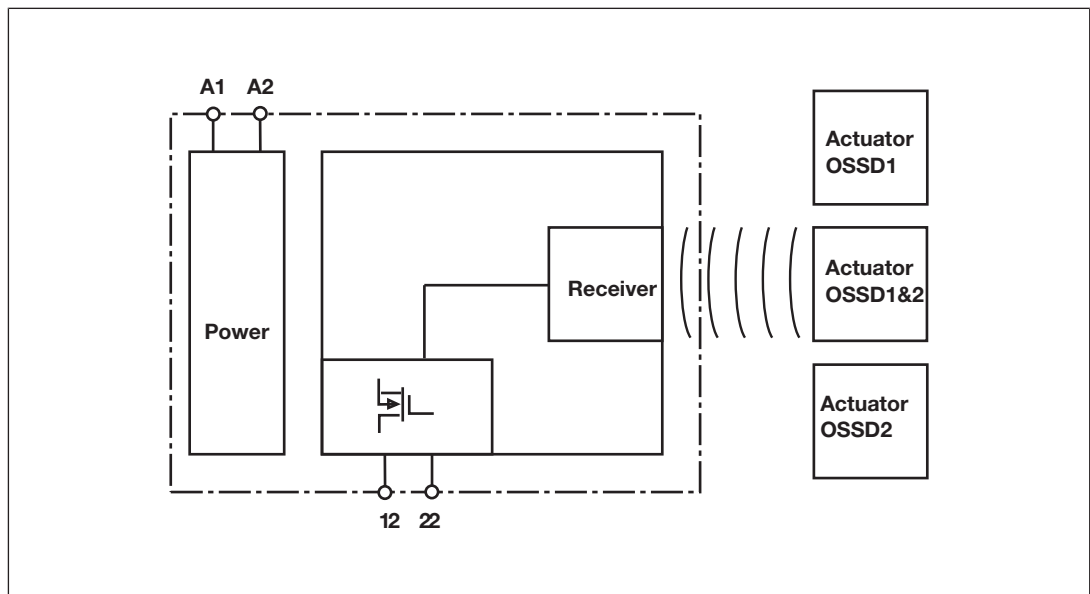

Operating distances

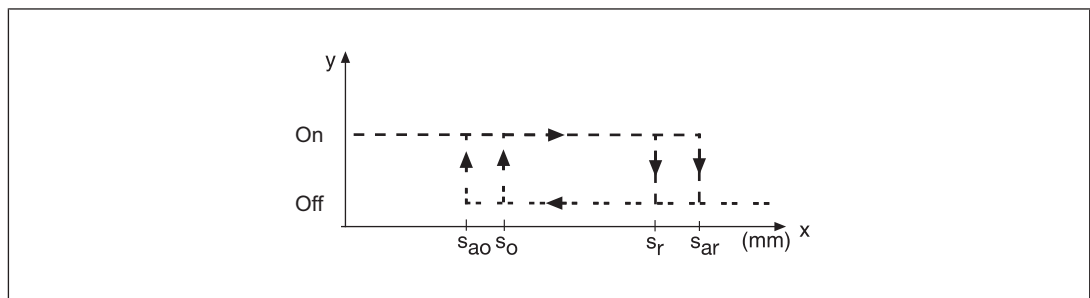

Legend:

- ▶ S_{ao} Assured operating distance: 15 mm
- ▶ S_o Typical operating distance: 21 mm
- ▶ S_r Typical release distance: 24 mm
- ▶ S_{ar} Assured release distance: 40 mm

Lateral and vertical offset

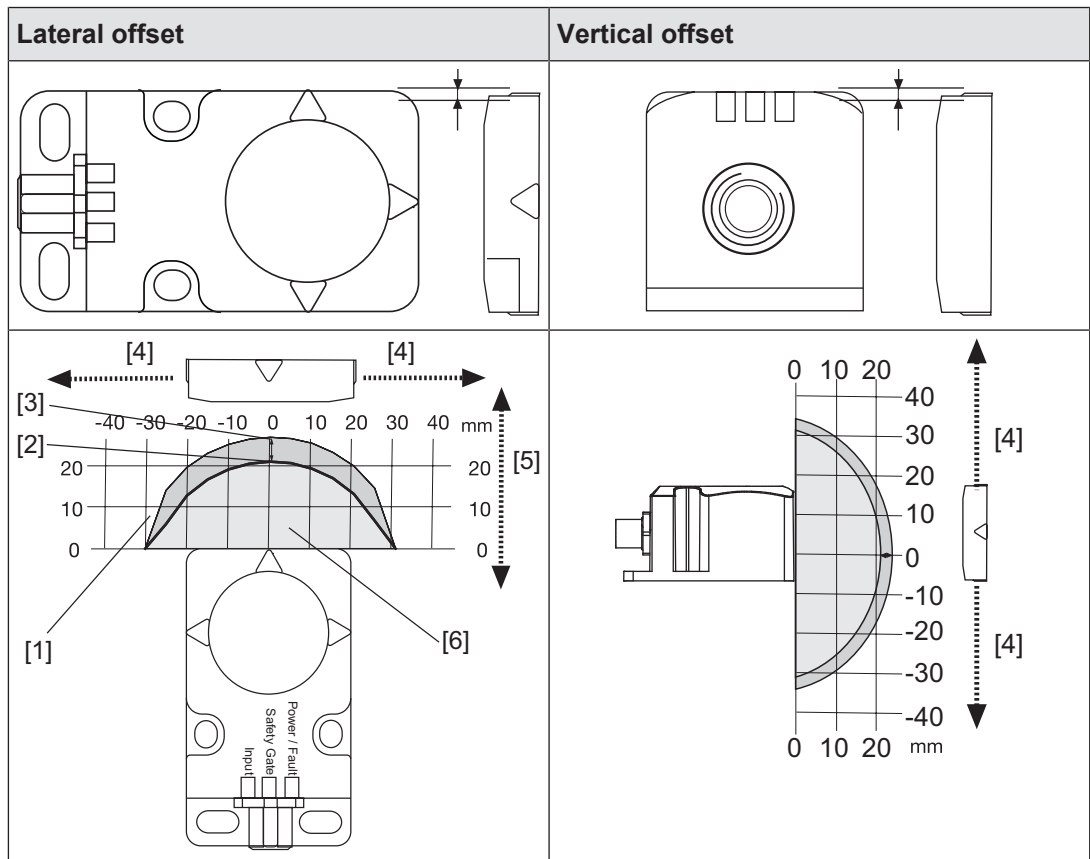

Legend

- [1] Hysteresis
- [2] Typical operating distance S_o
- [3] Typical release distance S_r
- [4] Offset in mm
- [5] Operating distance in mm
- [6] Response range

Distance between actuators

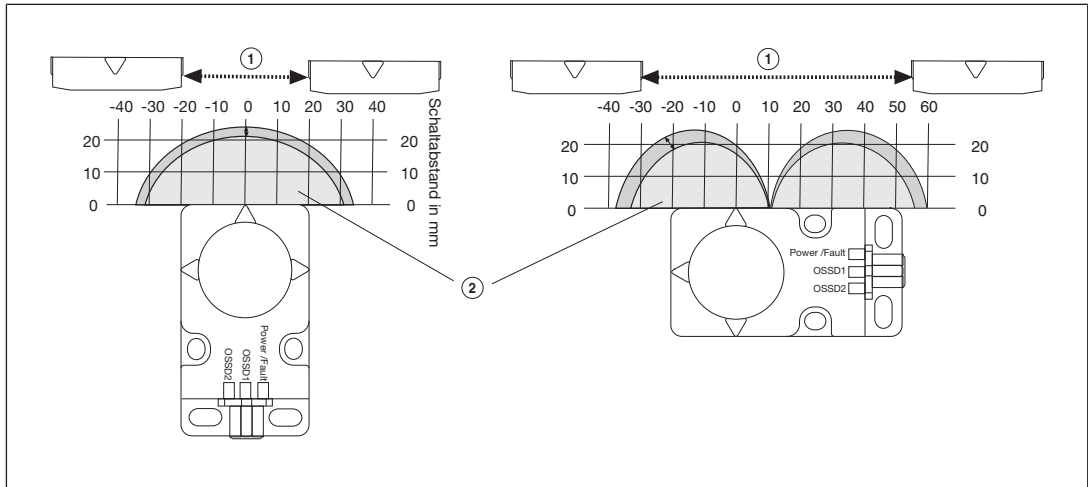

- ▶ [1]: Min. distance between 2 actuators: when the direction of actuation is from the front/ side
- ▶ [2]: Response range



NOTICE

To detect the actuator without error, it is necessary to maintain

- a minimum [time difference](#) [📖 18] between 2 actuators when the actuators approach the response range,
- the max. [approach speed](#) [📖 18].

Wiring

Please note:

- ▶ Information given in the "Technical details" must be followed.
- ▶ The power supply must meet the regulations for extra low voltages with protective separation (SELV, PELV).
- ▶ The inputs and outputs of the safety switch must have a protective separation to voltages over 60 VDC.



INFORMATION

Only use safety relays with a 24 VDC supply voltage. Safety relays with a wide-range power supply or in AC device versions have internal potential isolation and are not suitable as evaluation devices.

- ▶ The supply voltage to the safety switch must be protected with a 2 A to 4 A quick-acting fuse.
- ▶ Ensure the wiring and EMC requirements of IEC 60204-1 are met.

Pin assignment, connector and cable

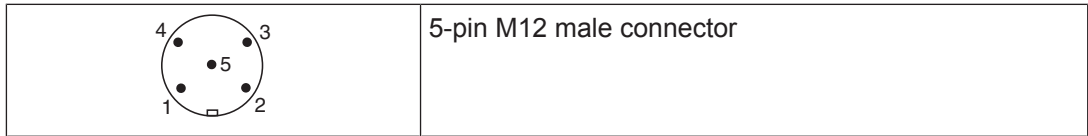

PIN	Pin designation	Function	Wire colour
1	A1	+24 UB	Brown
2	12	Output, channel1	White
3	A2	0 V UB	Blue
4	22	Output, channel2	Black
5	-	Do not connect	Grey

The wire colour also applies for the cable available from Pilz as an accessory.

Connection to evaluation devices

Make sure that the selected evaluation device has the following property:

- ▶ OSSD signals are evaluated through 2 channels with feasibility monitoring

Please note:

- ▶ Information given in the [Technical details \[18\]](#) must be followed.

Connection diagram, single connection

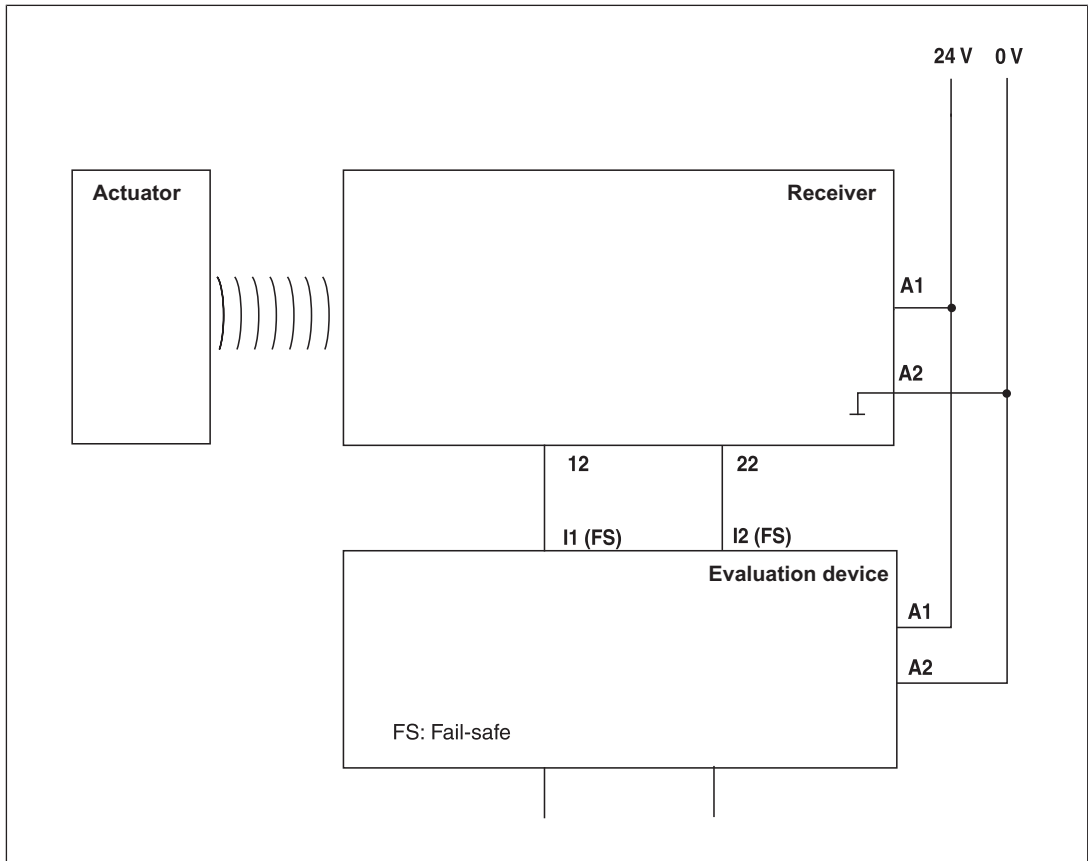

Suitable Pilz evaluation devices are, for example:

- ▶ PNOZelog for safety gate monitoring
- ▶ PNOZpower for safety gate monitoring
- ▶ PNOZsigma for safety gate monitoring
- ▶ PNOZ X for safety gate monitoring
- ▶ PNOZmulti for safety gate monitoring
Configure the switch in the PNOZmulti Configurator with switch type 3.
- ▶ PSS for safety gate monitoring with standard function block SB064, SB066 or FS_Safety Gate
- ▶ PSSuniversal PLC for safety gate monitoring with function block FS_SafetyGate

The correct connection to the respective evaluation device is described in the operating manual for the evaluation device. Make sure that the connection is made in accordance with the specifications in the operating manual for the selected evaluation device.

The connections to two evaluation devices are shown on the following pages, by way of example:

- ▶ PNOZ s3 and
- ▶ PNOZmulti

PNOZ s3

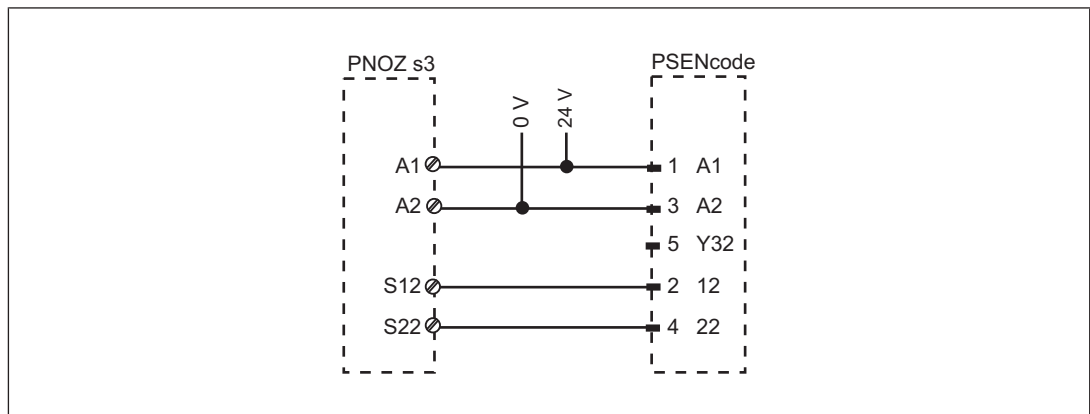

PNOZmulti

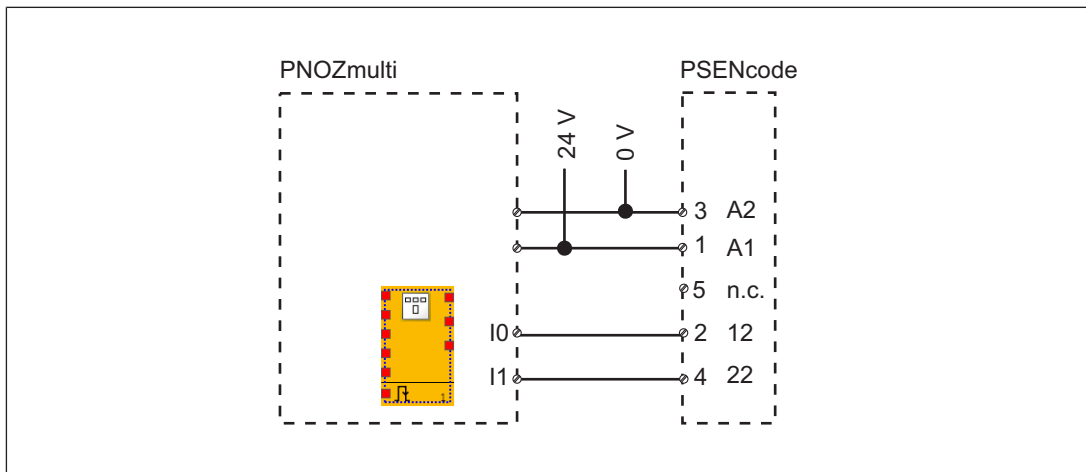

Fig.: Selection in the PNOZmulti Configurator PSENcode with three actuators as an example

Legend

- I0 Input OSSD
- I1 Input OSSD

Teaching in the actuator

Any Pilz actuator PSEN cs1.19) is detected as soon as it is brought into the response range.

Installation



CAUTION!

The unit's properties may be affected if installed in an environment containing electrically or magnetically conductive material. Please check the operating distances and the assured release distance.

- ▶ The safety switch and actuators should be installed opposite each other in parallel. Make sure that all the actuators are in the position intended for operating the safety switch, parallel to the safety switch.
- ▶ Safety switches and actuators should be permanently secured using M5 safety screws with a flat head (e.g. M5 cheese-head or pan head screws).
- ▶ Protect the actuator from contamination.
- ▶ Torque setting: Please note the information provided under [Technical details \[18\]](#).
- ▶ The distance between two safety switches must be maintained (see [Technical details \[18\]](#)).
- ▶ Make sure that the safety switch and actuator cannot be used as an end stop.

Procedure:

Fig.: Sensing faces on the sensor

1. Drill holes (for M5 screws) in the mounting surface to secure the actuator and sensor (see [Dimensions in mm](#) [📖 18]).
2. Use a screw to fix the sensor to the mounting surface.
Make sure that the sensor marking that is be used for operation can be operated using the actuator from the right side.
3. Do not fully tighten the second screw on the safety switch.
4. Use a screw to fix the actuator to the mounting surface.
Make sure that the actuator with the printed side points towards the marking on the sensor.
5. Do not fully tighten the second screw on the actuator.
6. Align the safety switch and tighten the screws.
7. Align the actuator and tighten the screws.

Adjustment

- ▶ The stated operating distances (see [Technical details](#) [📖 18]) only apply when the safety switch and actuator are installed facing each other in parallel. Operating distances may deviate if other arrangements are used.
- ▶ Note the maximum permitted lateral and vertical offset (see [Operating distances](#) [📖 9] and [Lateral and vertical offset](#) [📖 10]).

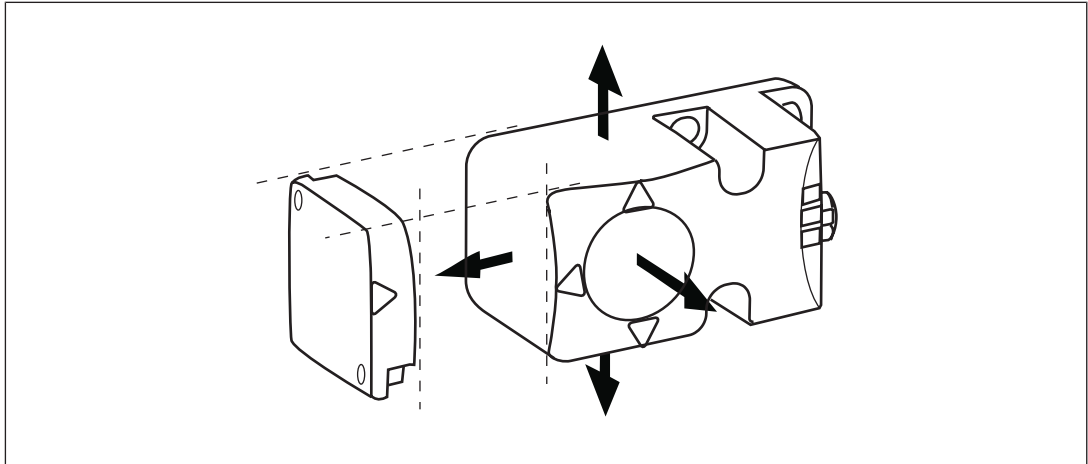
Operation**NOTICE**

The safety function should be checked after initial commissioning and each time the plant/machine is changed. The safety functions may only be checked by qualified personnel.

Check the function of the safety switch before commissioning.

Status indicators:

- ▶ "POWER/Fault" LED lights up green: The unit is ready for operation
- ▶ "OSSD1" LED lights up yellow and "OSSD2" LED is off
 - Actuator OSSD1 is in the response range
- ▶ "OSSD2" LED lights up yellow and "OSSD1" LED is off
 - Actuator OSSD2 is in the response range
- ▶ "OSSD1" and "OSSD2" LEDs light up yellow: Actuators OSSD1&2 are in the response range

Fault indicator:

- ▶ "POWER/Fault" LED lights up red: Error message.
Flashing codes for fault diagnostics are output to the "OSSD1" and "OSSD2" LEDs.
Remedy: Disconnect power supply and rectify error. Reconnect power supply.

Please note the different times for

- ▶ The switch-on delay after UB is applied
- ▶ The recovery time of the sensor and evaluation device.

Error display through flashing codes

The "OSSD1" or "OSSD2" LEDs send flash signals; an error code can be established from the number and sequence. The "Power/Fault" LED illuminates red.

Each error code is indicated by three short flashes of the "OSSD1" or "OSSD2" LED. After a longer pause, the LED will then flash at one second intervals. The number of LED flashes corresponds to a digit in the error code. The error code can consist of up to 3 digits. The digits are separated by a longer period without flashing. The entire sequence is constantly repeated.

Number of flashes	1 2 3 4 5 6 7 8 9 10 11 12 13 14 15 16
Decimal error code	1 2 3 4 5 6 7 8 9 10 11 12 13 14 15 0

Example:

Error code 1,4,1:

Flash frequency of the "OSSD1" or "OSSD2" LED

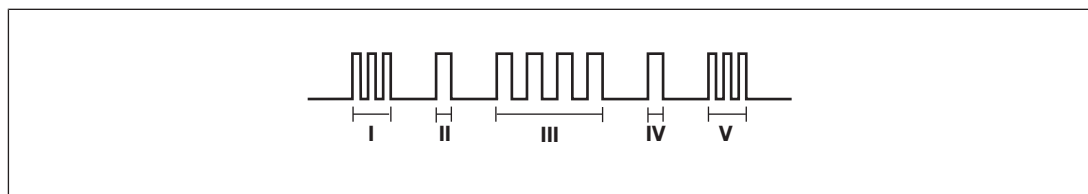

Meaning of flash frequency:

	Flash frequency	Meaning
I	3 times, short	Code for error message
II	Once, for one second each	Code for 1st digit
III	4 times, for one second each	Code for 2nd digit

	Flash frequency	Meaning
IV	Once, for one second each	Code for 3rd digit
V	3 times, short	Code for error message repeated

Table of error codes

Error code			
Decimal	Number of flashes	Description	Remedy
1.4.1	3x short – 1x long – 4x long – 1x long – 3x short	Wiring error	Rectify wiring error
1.12	3x short – 1x long – 12x long – 3x short	Wiring error	Rectify wiring error
1.13	3x short – 1x long – 12x long – 3x short	Wiring error	Rectify wiring error
14	3x short – 14x long – 3x short	Wiring error	Rectify wiring error
15	3x short – 15x long – 3x short	Wiring error	Rectify wiring error

Other flashing codes signal an internal error. Remedy: Change device.

Dimensions in mm

Safety switch

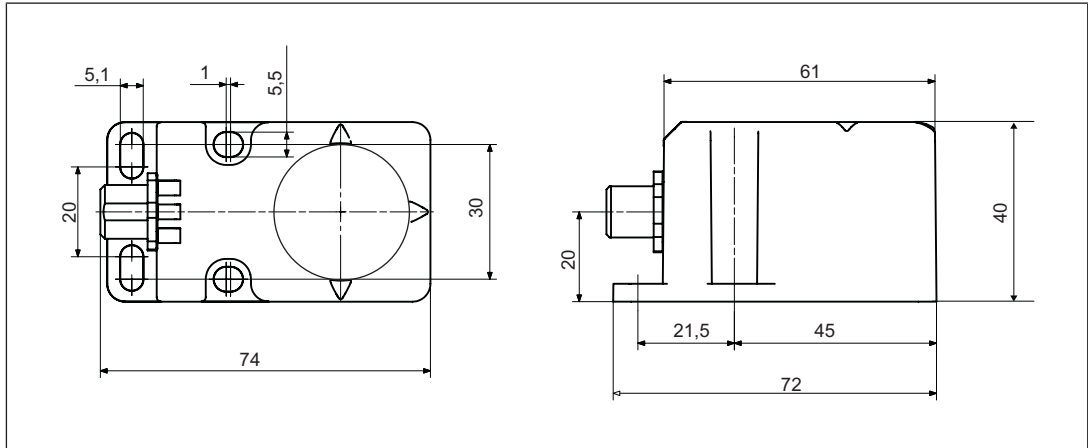

Actuator

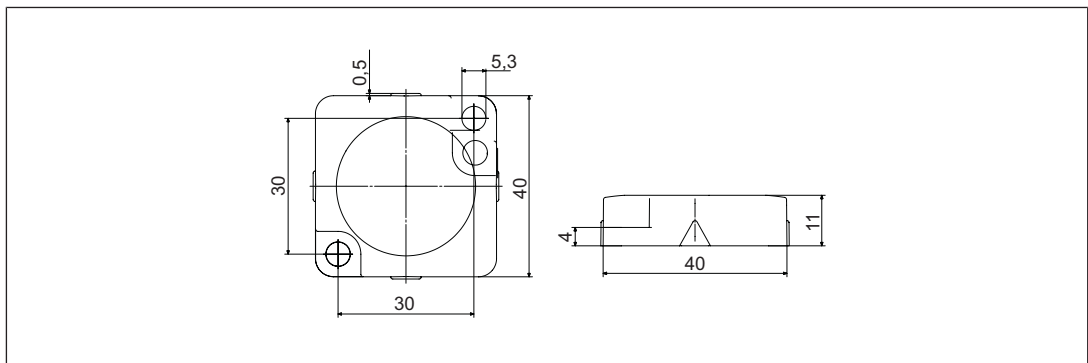

Technical details

General	540303	540304	540305
Approvals	CE, EAC (Eurasian), FCC, IC, TÜV, cULus Listed	CE, EAC (Eurasian), FCC, IC, TÜV, cULus Listed	CE, EAC (Eurasian), FCC, IC, TÜV, cULus Listed
Sensor's mode of operation	Transponder	Transponder	Transponder
Coding level in accordance with EN ISO 14119	Low	Low	Low
Design in accordance with EN ISO 14119	4	4	4
Classification in accordance with EN 60947-5-3	PDDB	PDDB	PDDB
Pilz coding type	Coded	Coded	Coded
Transponder	540303	540304	540305
Frequency band	122 kHz - 128 kHz	122 kHz - 128 kHz	122 kHz - 128 kHz
Max. transmitter output	7 dBm	7 dBm	7 dBm

Electrical data	540303	540304	540305
Supply voltage			
Voltage	24 V	24 V	24 V
Kind	DC	DC	DC
Voltage tolerance	-20 %/+20 %	-20 %/+20 %	-20 %/+20 %
Output of external power supply (DC)	2 W	2 W	2 W
Max. inrush current at UB	0,12 A	0,12 A	0,12 A
Max. switching frequency	1 Hz	1 Hz	1 Hz
Max. cable capacitance at the safety outputs			
No-load, PNOZ with relay contacts	40 nF	40 nF	40 nF
PNOZmulti, PNOZelog, PSS	70 nF	70 nF	70 nF
No-load current	50 mA	50 mA	50 mA
Semiconductor outputs	540303	540304	540305
OSSD safety outputs	2	2	2
Switching current per output	500 mA	500 mA	500 mA
Breaking capacity per output	12 W	12 W	12 W
Potential isolation from system voltage	No	No	No
Short circuit-proof	yes	yes	yes
Residual current at outputs	10 µA	10 µA	10 µA
Voltage drop at OSSDs	3,5 V	3,5 V	3,5 V
Lowest operating current	0 mA	0 mA	0 mA
Utilisation category in accordance with EN 60947-1	DC-12	DC-12	DC-12
Times	540303	540304	540305
Test pulse duration, safety outputs	450 µs	450 µs	450 µs
Switch-on delay			
after UB is applied	1,2 s	1,2 s	1,2 s
Actuator typ.	50 ms	50 ms	50 ms
Actuator max.	160 ms	160 ms	160 ms
Delay-on de-energisation			
Actuator typ.	30 ms	30 ms	30 ms
Actuator max.	260 ms	260 ms	260 ms
Supply interruption before de-energisation	20 ms	20 ms	20 ms
Simultaneity, channel 1 and 2 max.	∞	∞	∞

Environmental data	540303	540304	540305
Ambient temperature			
In accordance with the standard	EN 60068-2-14	EN 60068-2-14	EN 60068-2-14
Temperature range	-25 - 55 °C	-25 - 55 °C	-25 - 55 °C
Storage temperature			
In accordance with the standard	EN 60068-2-1/-2	EN 60068-2-1/-2	EN 60068-2-1/-2
Temperature range	-25 - 70 °C	-25 - 70 °C	-25 - 70 °C
Climatic suitability			
In accordance with the standard	EN 60068-2-78	EN 60068-2-78	EN 60068-2-78
Humidity	93 % r. h. at 40 °C	93 % r. h. at 40 °C	93 % r. h. at 40 °C
EMC	EN 60947-5-3	EN 60947-5-3	EN 60947-5-3
Vibration			
In accordance with the standard	EN 60947-5-2	EN 60947-5-2	EN 60947-5-2
Frequency	10 - 55 Hz	10 - 55 Hz	10 - 55 Hz
Amplitude	1 mm	1 mm	1 mm
Shock stress			
In accordance with the standard	EN 60947-5-2	EN 60947-5-2	EN 60947-5-2
Acceleration	30g	30g	30g
Duration	11 ms	11 ms	11 ms
Airgap creepage			
Overvoltage category	III	III	III
Pollution degree	3	3	3
Rated insulation voltage	75 V	75 V	75 V
Rated impulse withstand voltage	0,8 kV	0,8 kV	0,8 kV
Protection type			
Housing	IP67	IP67	IP67
Mechanical data	540303	540304	540305
Min. distance between 2 actuators with lateral approach	85 mm	85 mm	85 mm
Min. distance between 2 actuators with frontal approach	40 mm	40 mm	40 mm
Max. approach speed	80 mm/s	80 mm/s	80 mm/s
Min. time difference between the approach of the actuators	0,5 s	0,5 s	0,5 s
Actuator 1	PSEN cs1.19	PSEN cs1.19	PSEN cs1.19

Mechanical data	540303	540304	540305
Operating distances			
Assured operating distance Sao	15 mm	15 mm	15 mm
Typical operating distance So	21 mm	21 mm	21 mm
Assured release distance Sar	40 mm	40 mm	40 mm
Typical release distance Sr	24 mm	24 mm	24 mm
Repetition accuracy switching distances	10 %	10 %	10 %
Change of operating distance with temperature changes	+0,01mm/°C	+0,01mm/°C	+0,01mm/°C
Typ. Hysteresis	3 mm	3 mm	3 mm
Min. distance between safety switches	400 mm	400 mm	400 mm
Sensor flush installation in accordance with EN 60947-5-2	Yes, follow installation guidelines	Yes, follow installation guidelines	Yes, follow installation guidelines
Connection type	M12, 5-pin male connector	M12, 5-pin male connector	M12, 5-pin male connector
Material			
Top	PBT	PBT	PBT
Max. torque setting for fixing screws	1 Nm	1 Nm	1 Nm
Dimensions			
Height	75 mm	75 mm	75 mm
Width	40 mm	40 mm	40 mm
Depth	40 mm	40 mm	40 mm
Actuator dimensions			
Height	11 mm	11 mm	11 mm
Width	40 mm	40 mm	40 mm
Depth	40 mm	40 mm	40 mm
Weight of safety switch	130 g	130 g	130 g
Weight of actuator	20 g	20 g	20 g
Weight	190 g	150 g	170 g

Where standards are undated, the 2014-10 latest editions shall apply.

Safety characteristic data

The max. safety level that can be achieved depends on the number of actuators used. Diagnostics must be performed to achieve a higher safety level.

Number of actuators	Actuators used	Dia-agnostics	EN ISO 13849-1: 2015 PL	EN IEC 62061 SIL CL	EN IEC 62061 PFH [1/h]	t _M [year]	Comment
1	OSSD1&2	----	PL e (Cat. 4)	SIL CL 3	2,37E-09	20	(1)
2	OSSD1 OSSD2	----	PL c (Cat. 1)	SIL CL 1	4,52E-08	20	
2	OSSD1 OSSD2	X	PL d (Cat. 2)	SIL CL 2	2,52E-08	20	(2)
3	OSSD1&2 OSSD1 OSSD2	----	PL c (Cat. 1)	SIL CL 1	4,52E-08	20	
3	OSSD1&2	X	PL d (Cat. 2)	SIL CL 2	2,52E-08	20	
	OSSD1 OSSD2	X	PL c (Cat. 2)	SIL CL 1	4,52E-08	20	

(1) Prerequisites:

Dual-channel evaluation of OSSDs

The actuators OSSD1 and OSSD2 are unused and can never come within the sensor's response range.

(2) Requirements:

The actuator OSSD1&2 is unused and can never come within the sensor's response range.

Diagnostics

Diagnostics must detect stuck-at faults and faults in the sensor supply lines (e. g. shorts across contacts, short circuits, open circuits). To do this, a safety system must perform a feasibility check. Each time before the safety function is initiated, the safety switch must run through defined states. If this does not occur within a defined time (depending on the application) the programmable safety system must safely shut down the plant/machine. The behaviour of the feasibility check must be verified during initial commissioning.

Example:

Monitoring two positions of a turntable

1. Turntable on position 1 Actuator OSSD1 is detected
2. Turntable turns on position 2 Actuator OSSD2 is detected

Sequence of the defined states:

1. Actuator OSSD1 is detected
2. No actuator in the response range
3. Actuator OSSD2 is detected

If these states are not run through within the specified time, the programmable safety system switches off the turntable.

Supplementary data

Radio approval

USA/Canada

FCC ID: VT8-PSENCs1
IC: 7482A-PSENCs1

FCC/IC-Requirements:

This product complies with Part 15 of the FCC Rules and with Industry Canada licence-exempt RSS standards.

Operation is subject to the following two conditions:

- 1) this product may not cause harmful interference, and
- 2) this product must accept any interference received, including interference that may cause undesired operation.

Changes or modifications made to this product not expressly approved by Pilz may void the FCC authorization to operate this equipment.

NOTE: This equipment has been tested and found to comply with the limits for a Class A digital device, pursuant to Part 15 of the FCC Rules. These limits are designed to provide reasonable protection against harmful interference when the equipment is operated in a commercial environment. This equipment generates, uses, and can radiate radio frequency energy and, if not installed and used in accordance with the instruction manual, may cause harmful interference to radio communications. Operation of this equipment in a residential area is likely to cause harmful interference in which case the user will be required to correct the interference at his own expense.

Le présent produit est conforme aux CNR d'Industrie Canada applicables aux appareils radio exempts de licence. L'exploitation est autorisée aux deux conditions suivantes:

- (1) le produit ne doit pas produire de brouillage, et
- (2) l'utilisateur de le produit doit accepter tout brouillage radioélectrique subi, même si le brouillage est susceptible d'en compromettre le fonctionnement.

Order reference

System

Product type	Features	Connection type	Order no.
PSEN cs1.19n/PSEN cs1.19 1sw/3actuators	Safety gate system, coded, 3 actuators	5-pin M12 connector	540 303
PSEN cs1.19n/PSEN cs1.19 1sw+OSSD1&2	Safety gate system, coded, 1 actuators	5-pin M12 connector	540 304
PSEN cs1.19n/PSEN cs1.19 1sw+OSSD1+OSSD2	Safety gate system, coded, 2 actuators	5-pin M12 connector	540 305
PSEN cs1.19n (switch)	Safety switch, coded	5-pin M12 connector	540 353
PSEN cs1.19 OSSD1&2	Actuator, coded		540 380
PSEN cs1.19 OSSD1	Actuator, coded		540 382
PSEN cs1.19 OSSD2	Actuator, coded		540 383

Accessories

Installation materials

Product type	Features	Order no.
PSEN bracket	Mounting bracket	532 110
PSEN mag/cs bracket straight	Mounting aid	532 111

PSEN screw M5x10 10pcs	Safety screws made from stainless steel with one-way slot	540 311
PSEN screw M5x20 10pcs	Safety screws made from stainless steel with one-way slot	540 312
PSEN cs1/2 bracket cable fix	Mechanical protection against defeat, protecting against unauthorised cable disconnection or damage for safety switches PSENcode cs1/2, PSENcode cs5/6 M12, PSENslock	532 112

Cable

Product type	Connection 1	Connection 2	Length	Order No.
PSS67/PDP67 cable M12-5sf	Straight, M12, 5-pin, socket	Straight, M12, 5-pin, connector	3 m	380 208
			5 m	380 209
			10 m	380 210
			20 m	380 220
			30 m	380 211
PSS67/PDP67 cable M12-5af	Angled, M12, 5-pin, socket	Angled, M12, 5-pin, connector	3 m	380 212
			5 m	380 213
			10 m	380 214
			30 m	380 215
PSEN cable M12-5sf	Straight, M12, 5-pin, socket	Open cable	3 m	630 310
			5 m	630 311
			10 m	630 312
			20 m	630 298
			30 m	630 297
PSEN cable M12-5af	Angled, M12, 5-pin, socket	Open cable	3 m	630 347
			5 m	630 348
			10 m	630 349
			30 m	630 350
PDP67 F 8DI ION	Decentralised input module IP67 for PNOZmulti			773 600

EC declaration of conformity

This product/these products meet the requirements of the directive 2006/42/EC for machinery of the European Parliament and of the Council. The complete EC Declaration of Conformity is available on the Internet at www.pilz.com/downloads.

Representative: Norbert Fröhlich, Pilz GmbH & Co. KG, Felix-Wankel-Str. 2, 73760 Ostfildern, Germany